

Iridium Dioxygen Complexes in the Oxidation of Substrates: Kinetics, Mechanism, and Steric and Electronic Effects in the Oxidation of CO, CO₂, PPh₃, and SO₂ by RIr(O₂)(CO)L₂ (R = Me, Ph, Np; L = PPh₃, P(*p*-tolyl)₃, PPh₂Me, P(*p*-C₆H₄OMe)₃)

Holly J. Lawson and Jim D. Atwood*

Contribution from the Department of Chemistry, University at Buffalo, State University of New York, Buffalo, New York 14214. Received January 10, 1989

Abstract: The preparation, characterization, and oxygen-transfer reactivity of the iridium dioxygen complexes RIr(O₂)(CO)L₂ (R = Me, Ph, Np; L = PPh₃, P(*p*-tolyl)₃, PPh₂Me, PMe₂Ph, and P(*p*-C₆H₄OMe)₃) are reported. These complexes oxidize carbon monoxide to carbonate, sulfur dioxide to sulfate, carbon dioxide to peroxycarbonate, and triphenylphosphine to triphenylphosphine oxide but are relatively inert to other possible substrates. The kinetics of the oxidations of CO and CO₂ are reported and indicate a mechanism of reversible conversion of the dioxygen from bidentate to monodentate followed by reaction with free substrate in solution. The phosphine ligand dependence on the rate of CO oxidation indicates that more electron density slightly increases the rate of oxygen transfer and that steric interactions impede the rate.

Oxidation of species by complexes derived from molecular oxygen remains a major focus of organic and inorganic research.¹⁻⁴ Square-planar iridium complexes react with dioxygen, forming five-coordinate dioxygen complexes.⁵⁻⁷ Previously we communicated the oxidation of CO to CO₃²⁻ by an iridium dioxygen complex,⁸ now we report the dependence on substrate and steric and electronic factors in oxidation reactions utilizing iridium dioxygen complexes.

Experimental Section

IrCl₃·xH₂O was borrowed from Johnson Matthey. All phosphines were purchased from Strem Chemical Co. O₂(99%), CO(99%), and CO₂ (bone dry grade) were purchased from Union Carbide Corp. (Linde Div.). SO₂ (anhydrous) and CO (cp grade) were purchased from Matheson. ¹³C, ¹⁸O, and ¹⁸O₂ were obtained from MSD isotopes. Methylolithium and phenyllithium were used as received from Aldrich Chemical Co. Neopentylolithium was prepared by variation of published procedure.⁹ The synthesis of tri-*p*-tolylphosphine oxide is outlined in the literature.¹⁰ Triphenylphosphine oxide was made in the same manner as OP(*p*-tolyl)₃.

Benzene, toluene, tetrahydrofuran, diethyl ether, cyclohexane, hexanes, pentane, and cyclopentane were all dried by refluxing over CaH₂, distilling onto Na/benzophenone, refluxing over Na/benzophenone, and distilling into an air-free container. The purified solvents were stored in an inert-atmosphere glovebox. CH₂Cl₂, CD₂Cl₂, CDCl₃, and C₆D₆ were all purified by overnight stirring over CaH₂ followed by distillation on the vacuum line.

Elemental analyses were performed by Oneida Research Services, Inc. Infrared spectra of KBr pellets and solutions were measured on a Beckman 4240 infrared spectrophotometer in the region 2200-750 cm⁻¹. ¹H, ³¹P, and ¹³C NMR spectra were measured on a JEOL FX90Q spectrometer. All ³¹P NMR spectra were collected by using an external

Table I.

compound	solvent	δ ^a
P(<i>p</i> -tolyl) ₃	C ₆ D ₆	-8.0
PPh ₃	C ₆ D ₆	-5.0
OP(<i>p</i> -tolyl) ₃	C ₆ D ₆	29.5
OPPh ₃	C ₆ D ₆	28.4
P(OPh) ₃	C ₆ D ₆	128.4
(CH ₃)Ir(P(<i>p</i> -tolyl) ₃) ₂ (CO)	C ₆ D ₆	-4.0
(CH ₃)Ir(P(<i>p</i> -tolyl) ₃) ₂ (CO)(O ₂)	C ₆ D ₆	4.5

^a³¹P NMR chemical shifts referenced relative to H₃PO₄.

deuterium lock with the H₃PO₄ chemical shift being assigned to 0 ppm; all other peaks are listed relative to this reference. The observed ³¹P chemical shifts of selected species of interest are listed in Table I.

Kinetics. All kinetic measurements were made in water-jacketed kinetic vessels. A standard run involving 1 atm of reactant gas utilized 50 mg of RIrP₂(CO)(O₂) dissolved in 10 mL of benzene. The vessel was then purged with the reactant gas and heated to 50 °C by using a Haake FS constant-temperature circulator. Periodic sampling was undertaken by syringe with an 8-in. needle through a septum on the gas-inlet tube of the kinetic vessel. Variable gas concentration kinetic runs were set up in a similar manner with a gas bulb. The gas bulb was evacuated on the vacuum line and then, for reactant gas pressures of less than 0.56 atm, partially filled with reactant gas. The bulb was then placed on the kinetic vessel, and the stopcock connecting the pump tubing to the vessel was opened. The entire vessel (minus the bulb) was evacuated and backfilled with N₂. The stopcocks to the bulb were then opened, and additional N₂ was slowly added until the total pressure was 1 atm. For experiments using reactant gas concentrations greater than 0.56 atm, N₂ was used to fill the gas bulb partially and the reactant gas was used to backfill the entire apparatus to 1 atm. The gases were then mixed for 5 min by using a Masterflex 7016 tubing pump. The stopcocks to the tubing were then closed to prevent possible leakage around the tubing/glass interfaces, and the vessel was heated as previously described.

All reactions were monitored by infrared spectroscopy following the growth of the absorbance at 1675 cm⁻¹ assigned to the C-O double-bond stretch of either the carbonate or the peroxycarbonate ligand.

All data were evaluated by employing the ln [(A_∞ - A_t)/(A_∞ - A₀)] vs time equation in the KINPLOT.PAS program.¹¹ Duplicate runs were made for all experimental conditions, and reported rate constants are averages.

Isotopic-Labeling Study. Dioxygen complex (50 mg) was dissolved in 30 mL of benzene in a pressure tube. On the vacuum line, three freeze-pump-thaw cycles were used to degas the solution. A Toepler pump was then used to transfer 1 atm of labeled carbon monoxide to the tube. The mixture was then stirred for 4 days in the absence of light.

(11) Ruszczyk, R. Thesis, S.U.N.Y. at Buffalo, 1985, p 191.

(1) Sheldon, R. A.; Kochi, J. K. *Metal-Catalyzed Oxidations of Organic Compounds*; Academic: New York, 1981.

(2) Valentine, J. S. *Chem. Rev.* **1973**, *73*, 235.

(3) Collman, J. P. *Acc. Chem. Res.* **1977**, *10*, 265.

(4) Niederhoffer, E. C.; Timmons, J. H.; Martell, A. E. *Chem. Rev.* **1984**, *84*, 137.

(5) Dahlenburg, L.; Nast, R. *J. Organomet. Chem.* **1974**, *71*, C49.

(6) Dahlenburg, L.; Nast, R. *J. Organomet. Chem.* **1976**, *110*, 395.

(7) Vaska, L. *Acc. Chem. Res.* **1976**, *9*, 175.

(8) Lawson, H. J.; Atwood, J. D. *J. Am. Chem. Soc.* **1988**, *110*, 3680.

(9) (a) Banks, M. A., personal conversations. (b) Schrock, R. R.; Fellmann, J. D. *J. Am. Chem. Soc.* **1978**, *100*, 3359.

(10) (a) Temple, R. D.; Tsuno, Y.; Leffler, J. E. *J. Org. Chem.* **1963**, *28*, 2495. (b) Hays, H. R.; Peterson, D. J. In *Organic Phosphorus Compounds*; Kosolapoff, G. M., Maier, L., Eds.; Interscience: New York, 1972; Vol. 3, p 346.

Table II. Infrared Stretching Frequencies as the Result of Various Reactions with Isotopically Labeled Compounds^a

iridium complex	CO gas	product					
		carbonyl			carbonate ^b		
		C≡O	C≡ ¹⁸ O	¹³ C≡O	C=O	¹³ C=O	C= ¹⁸ O
CH ₃ Ir(P(<i>p</i> -tolyl) ₃) ₂ (CO)(O ₂)	CO	2000			1675 1620		
CH ₃ Ir(P(<i>p</i> -tolyl) ₃) ₂ (¹³ CO)(O ₂)	CO			1950	1677 1623		
CH ₃ Ir(P(<i>p</i> -tolyl) ₃) ₂ (C ¹⁸ O)(O ₂)	CO	2000	1950		1675 1620		
CH ₃ Ir(P(<i>p</i> -tolyl) ₃) ₂ (CO)(¹⁸ O ₂)	CO	1995					1654 1610
CH ₃ Ir(P(<i>p</i> -tolyl) ₃) ₂ (CO)(O ₂)	¹³ CO	2000				1637 1575	
CH ₃ Ir(P(<i>p</i> -tolyl) ₃) ₂ (CO)(O ₂)	C ¹⁸ O	1995					1655 1617
CH ₃ Ir(P(<i>p</i> -tolyl) ₃) ₂ (C ¹⁸ O ₃)(CO)		2003					1653 1615

^aAll frequencies are in cm⁻¹ as seen from KBr pellets. ^bThe C–O single-bond stretch of the carbonate appears to be part of an absorbance band at 1267 cm⁻¹. When ¹³C or ¹⁸O is incorporated into the carbonate, a shoulder appears at 1250 cm⁻¹.

Solvent was removed by rotary evaporator, and if the resultant product was tarlike, the solid was titrated with cyclohexane to produce an off-white powder. Products were analyzed by monitoring changes in absorption in the C–O double- and triple-bond regions of the infrared spectrum upon ¹³C or ¹⁸O labeling. The C–O single-bond stretch could not be conclusively assigned due to the presence of other absorbances in that region. The assignment of a portion of the absorption at 1267 cm⁻¹ to the C–O single-bond stretch is made on the basis of the appearance of a shoulder at 1250 cm⁻¹ when either ¹³C or ¹⁸O is incorporated. Table II lists the isotopically labeled species.

Syntheses. All *trans*-Ir(CO)L₂Cl complexes were prepared by procedures previously described.^{12–14} Yields and spectra are as follows: L = PPh₃, yield (94%), IR (KBr) (ν_{CO} = 1955 cm⁻¹); L = P(*p*-tolyl)₃, yield (81%), IR (KBr) (ν_{CO} = 1957 cm⁻¹); L = P(*p*-C₆H₄OMe)₃, yield (68%), IR (KBr) (ν_{CO} = 1944 cm⁻¹); L = PPh₂Me, ¹H NMR (CDCl₃) δ 2.16 (t, 6 H), 7.35 (m, 20 H), ³¹P NMR (CDCl₃) δ 25 (s), IR (KBr) ν_{CO} = 1950 cm⁻¹; L = PPhMe₂, yield (87%), ¹H NMR (CDCl₃) δ 2.1 (t, 12 H), 7.5 (m, 12 H), ³¹P NMR (CDCl₃) δ (25 (s), IR (KBr) ν_{CO} = 1955 cm⁻¹.

All *trans*-R₂Ir(CO)L₂ complexes were prepared by reaction of the chloride species with lithium reagents.^{5,15,16} Yields and spectra are as follows: L = PPh₃ and R = Me, IR (benzene) ν_{CO} = 1937 cm⁻¹; L = P(*p*-tolyl)₃ and R = Me, yield (89%), IR (KBr) ν_{CO} = 1935 cm⁻¹; L = P(*p*-C₆H₄OMe)₃ and R = Me, anal. calcd for C₄₄H₄₅IrO₇P₂, C 56.22, H 4.83, found C 55.55, H 4.72, IR (KBr) ν_{CO} = 1926 cm⁻¹, ¹H NMR (C₆D₆) δ 1.29 (t, 3 H), 3.81 (s, 17 H), 7.42 (m, 25 H); L = PPhMe₂ and R = Me, IR (cyclohexane) ν_{CO} = 1938 cm⁻¹; L = PPh₂Me and R = Me, IR (KBr) ν_{CO} = 1925 cm⁻¹, ¹H NMR (CDCl₃) δ 1.80 (t, 3 H), 2.35 (t, 6 H), 7.35 (m, 19 H); L = PCy₃ and R = Me, anal. calcd for C₃₈H₆₉IrO₂P₂, C 57.53, H 8.74, found C 56.52, H 8.51, IR (KBr) ν_{CO} = 1908 cm⁻¹; L = P(*p*-tolyl)₃ and R = Ph, yield 70%, IR (KBr) ν_{CO} = 1950 cm⁻¹.

The dioxygen complexes were all prepared by reaction of dioxygen with *trans*-R₂Ir(CO)L₂ by the procedure described below for R = CH₃, L = PPh₃. *trans*-CH₃Ir(PPh₃)₂(CO) (200 mg) was dissolved in a minimum of cyclohexane, and the yellow solution stirred under an atmosphere of O₂ in the dark. The off-white dioxygen product, which is insoluble in cyclohexane, precipitated as it formed. The reaction was complete in 20 min. The product was filtered through a fine glass frit and washed with cyclohexane: yield 77%; IR (KBr) ν_{CO} = 1965, ν_{OO} = 826 cm⁻¹; ¹H NMR (CDCl₃) δ 0.77 (t, 3 H), 7.44 (m, 30 H). Yields and spectra of the other dioxygen complexes are as follows: MeIr(P(*p*-tolyl)₃)₂(CO)(O₂): yield 76%; IR (KBr) ν_{CO} = 1960, ν_{OO} = 826 cm⁻¹; ¹H NMR (C₆D₆) δ 1.46 (t, 3 H (J_{PH} = 8.84 Hz)), 1.96 (s, 18 H), 6.96 (m, 11 H), 7.83 (m, 13 H); ³¹P NMR (C₆D₆) δ 4.5 (s); anal. calcd for C₄₄H₄₅IrO₇P₂, C 54.37, H 4.67, found C 54.60, H 4.70; IR (KBr) ν_{CO} = 1962, ν_{OO} = 824 cm⁻¹. NpIr(P(*p*-tolyl)₃)₂(CO)(O₂): yield 61%; IR

(KBr) ν_{CO} = 1965, ν_{OO} = 825 cm⁻¹. MeIr(PPh₂Me)₂(CO)(O₂) was prepared by a solid-state reaction, covered from light, in a desiccator, for 3.5–4 h: IR (KBr) indicates ν_{CO} = 1962 and ν_{OO} = 850 cm⁻¹.

Isotopically Labeled Compounds. ¹³CO, C¹⁸O, and ¹⁸O₂ were used to prepare isotopically labeled species. The infrared stretches were as follows: CH₃Ir(P(*p*-tolyl)₃)₂(¹⁸O₂), 777 cm⁻¹; CH₃Ir(P(*p*-tolyl)₃)₂(¹³CO), 1907 cm⁻¹; CH₃Ir(P(*p*-tolyl)₃)₂(C¹⁸O), 1910 cm⁻¹.

(Carbonyl)carbonylmethylbis(tri-*p*-tolylphosphine)iridium(III). (CH₃)Ir(P(*p*-tolyl)₃)₂(CO)(O₂) (50 mg) was dissolved in 10 mL of benzene in a water-jacketed reaction vessel. The apparatus was purged with CO and stirred at 50 °C for 15 h. All solvent was removed by rotary evaporator, and the remaining tar was stirred in cyclohexane to titrate the product to a grey-white solid. Recrystallization was achieved from toluene at 0 °C. An alternate synthesis involved dissolving 50 mg of (CH₃)Ir(P(*p*-tolyl)₃)₂(CO)(O₂) in 10 mL of benzene in a pressure bottle. The vessel was then purged 3× with CO and the solution was stirred at a pressure of 2 atm for 3 days. Workup and recrystallization were performed as outlined above: IR (KBr) ν_{CO} = 2000, ν_{CO₃} = 1680, 1625, 1267 cm⁻¹; ¹H NMR (C₆D₆) δ 7.8 (m, 12 H), 7.0 (m, 12 H), 2.0 (s, 18 H), 1.44 (t, J_{P-H} = 6.26 Hz, 3 H). This compound was also made with ¹³C enrichment in the carbonate ligand by reacting the dioxygen complex with ¹³CO.

Carbonylmethylbis(*p*-tolylphosphine)(peroxycarbonato)iridium(III). This reaction was run similar to the reaction with CO except that CO₂ gas was reacted for a period of 24 h: IR (KBr) ν_{CO} = 2010, ν_{OO(O)CO} = 1675, ν_{OO} = 772 cm⁻¹.

Reaction of (CH₃)Ir(P(*p*-tolyl)₃)₂(CO)(O₂) with PPh₃. (CH₃)Ir(P(*p*-tolyl)₃)₂(CO)(O₂) (50 mg, 5.71 × 10⁻⁵ mol) was dissolved in 7 mL of benzene. PPh₃ (149 mg, 5.69 × 10⁻⁴ mol, 5 equiv) was added, and the solution was stirred in the dark. Periodic monitoring by infrared spectroscopy showed the disappearance of the absorbance at 1960 cm⁻¹ and the growth of peaks at 1940 and 1190 cm⁻¹. The reaction appeared complete after 5 h. The product was isolated by removal of solvent by rotary evaporator: IR (KBr) ν_{CO} = 1945, ν_{OP} = 1190 cm⁻¹. This reaction was also monitored by ³¹P NMR spectroscopy. (CH₃)Ir(P(*p*-tolyl)₃)₂(CO)(O₂) (10 mg, 1.14 × 10⁻⁵ mol) and PPh₃ (15 mg, 5.73 × 10⁻⁵ mol, 5 equiv) were dissolved in 0.5 mL of CDCl₃. An initial ³¹P NMR spectrum indicated the presence of 2 peaks at δ 7 and -5. Periodic monitoring shows the gradual growth of peaks at δ -4, 28, and a small peak at -11, and the complete disappearance of the δ 7 peak. The ³¹P NMR spectra cease displaying changes after 4 h.

Reaction of (CH₃)Ir(P(*p*-tolyl)₃)₂(CO) with SO₂. Formation of (CH₃)Ir(P(*p*-tolyl)₃)₂(CO)(SO₂). In an inert-atmosphere glovebox, 25 mg of (CH₃)Ir(P(*p*-tolyl)₃)₂(CO) (2.96 × 10⁻⁵ mol) was dissolved in a minimum of cyclohexane in a Schlenk flask. The flask was then removed from the box and flushed with SO₂ for 5 min. During this time the yellow solution turned bright green and a precipitate formed. The mixture was stirred for another hour, after which the solvent (only slightly colored at this time) was removed by vacuum. The solid was brought into the box, and an infrared spectrum indicated a single product. Anal. Calcd for C₄₄H₄₅IrP₂O₃S: C, 58.20; H, 5.00. Found: C, 58.43; H, 4.88. IR (KBr) ν_{CO} = 1993, ν_{SO} = 1177, 1163 (sh), 1035 cm⁻¹.

Carbonylmethyl(sulfato)bis(*p*-tolylphosphine)iridium(III). (A) (CH₃)Ir(P(*p*-tolyl)₃)₂(CO)(O₂) (50 mg, 5.71 × 10⁻⁵ mol) was dissolved in 15 mL of benzene. SO₂ was bubbled through the yellow solution for 3 min, during which time the solution turned clear. The solution was stirred at room temperature for another 1.5 h. The solvent was removed

(12) Vrieze, K.; Collman, J. P.; Sears, Jr., C. T.; Kubota, M. *Inorg. Synth.* **1968**, *11*, 101, and references therein.

(13) Collman, J. P.; Kang, J. W. *J. Am. Chem. Soc.* **1967**, *89*, 844.

(14) Smith, L. R.; Lin, S. M.; Chen, M. G.; Mondal, J. U.; Blake, D. M. *Inorg. Synth.* **1981**, *21*, 97.

(15) (a) Rees, W. M.; Churchill, M. R.; Li, Y. J.; Atwood, J. D. *Organometallics* **1985**, *4*, 1162. (b) Rappoli, B. R.; Churchill, M. R.; Janik, T. S.; Rees, W. M.; Atwood, J. D. *J. Am. Chem. Soc.* **1987**, *109*, 5145.

(16) (a) Rappoli, B. R. Thesis, S.U.N.Y. at Buffalo, 1987. (b) Rausch, M. D.; Moser, G. A. *Inorg. Chem.* **1974**, *13*, 11. (c) Yagupsky, G.; Brown, C. K.; Wilkinson, G. *J. Chem. Soc. A* **1970**, 1392.

Table III. Properties and Infrared Stretching Frequencies (KBr Pellets) for Iridium Complexes

R, L	R ₂ IrL ₂ ⁺ (CO)(O ₂) ⁻			R = Cl ν _{CO}
	R ₂ IrL ₂ (CO) ν _{CO}	ν _{CO}	ν _{OO}	
Me, PCy ₃	1908			1930
Me, PMe ₂ Ph	1938 ^a	1963	843	1955
Me, PPh ₂ Me	1925	1962	850	1950
Me, P(<i>p</i> -CH ₃ OC ₆ H ₄) ₃	1926	1962	825	1946
Me, P(<i>p</i> -tolyl) ₃	1935	1960	826	1957
Ph, P(<i>p</i> -tolyl) ₃	1950	1975	865	1957
Np, P(<i>p</i> -tolyl) ₃	1930	1965	825	1957
O ₂ CH, P(<i>p</i> -tolyl) ₃	1955	1985	857	1957
PPh ₃	1937	1965	826	1955

^a Hexane solution.

by rotary evaporator, and the white solid was scraped from the sides of the flask: IR (KBr) ν_{CO} = 2010, ν_{SO₄} = 1267, 1155, 905, 865, 680, 657, 564 cm⁻¹. Reaction with CH₃Ir(P(*p*-tolyl)₃)₂(CO)(¹⁸O₂) was run in exactly the same manner. New absorbances observed in the infrared spectrum are ν = 1263, 1133, 905, 831, 682, 640, 552 cm⁻¹.

(B) (CH₃)Ir(P(*p*-tolyl)₃)₂(SO₂) was dissolved in 10 mL of benzene and stirred under O₂ for 19 h. During this time the lime-green solution turned to dark yellow-green. The solvent was removed by rotary evaporator, and a KBr pellet was made with the resulting solid. The infrared spectrum was identical with that found when (CH₃)Ir(P(*p*-tolyl)₃)₂(CO)(O₂) reacts with SO₂.

Results and Discussion

Addition of dioxygen to *trans*-R₂Ir(CO)L₂ occurs in the solid state and in solution. The dioxygen complexes are not stable in humid conditions, and care must be taken during the synthesis and storage to limit exposure to water. Prolonged exposure to oxygen in solution results in decomposition to a blue-green species; the decomposition of R₂IrP₂(CO)(O₂) complexes has not been fully elucidated. Because of the decomposition, synthesis of each dioxygen compound is performed so that the product can be isolated soon after formation. Reaction of dioxygen with *trans*-CH₃Ir(P(*p*-tolyl)₃)₂(CO) is executed with minimal effects of prolonged dioxygen exposure by using cyclohexane as the reaction solvent; the dioxygen adduct, CH₃Ir(P(*p*-tolyl)₃)₂(CO)(O₂), is insoluble in cyclohexane and precipitates from solution as it forms.

Synthesis of CH₃IrP₂(CO)(O₂) where P = PPh₂Me or PMe₂Ph was complicated by the decomposition since these complexes are very reactive and are difficult to precipitate from solution. The most successful synthesis of these two dioxygen compounds was performed by air oxidation of the *trans*-CH₃IrP₂(CO) compounds in the solid state. Even in this slow oxidation of *trans*-CH₃Ir(PMe₂Ph)₂(CO) some decomposition was observed. NpIr(P(*p*-tolyl)₃)₂(CO)(O₂) forms reversibly in solution and is in equilibrium with the 16-electron complex, *trans*-NpIr(P(*p*-tolyl)₃)₂(CO):

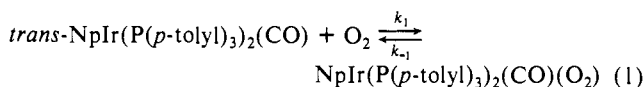

This equilibrium appears to lie to the left, $k_1 < k_{-1}$, and it is only when the reaction is forced to the right by precipitation of NpIr(P(*p*-tolyl)₃)₂(CO)(O₂) that the dioxygen adduct can be isolated.

Table III lists all of the 16- and 18-electron complexes along with the carbonyl and dioxygen ligand infrared stretching frequencies associated with each complex.

Reactions of the Dioxygen Complexes. Reaction of CH₃Ir(P(*p*-tolyl)₃)₂(CO)(O₂) with PPh₃ was characterized by both infrared and ³¹P NMR spectroscopy. Infrared spectra showed that the dioxygen complex (ν_{CO} = 1960 cm⁻¹) was completely converted to *trans*-CH₃Ir(P(*p*-tolyl)₃)₂(CO) (ν_{CO} = 1945 cm⁻¹) and triphenylphosphine oxide (ν_{OP} = 1190 cm⁻¹). This conclusion was reinforced by the ³¹P NMR data, which showed the disappearance of the resonance due to the dioxygen complex, CH₃Ir(P(*p*-tolyl)₃)₂(CO)(O₂) (δ 7), and the growth of resonances at δ -4 and 28, which correspond to *trans*-CH₃Ir(P(*p*-tolyl)₃)₂(CO) and OPPh₃. The identity of these resonances has been confirmed, not

Table IV. Fundamental Vibrational Modes for Labeled and Unlabeled SO₄²⁻ on CH₃Ir(P(*p*-tolyl)₃)₂(CO)(SO₄)

	ν ₁	ν ₂	ν ₃	ν ₄
¹⁶ O ₂	865	564	1281 1155 905	680 657
¹⁸ O ₂	831	552	1263 1135 905	682 640

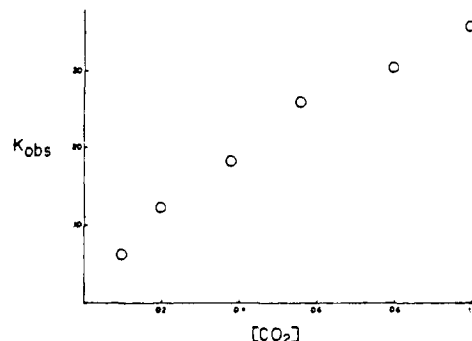
**Figure 1.** Dependence of k_{obs} on the concentration of CO₂.

only by comparison to standard samples but also through the addition of CH₃Ir(P(*p*-tolyl)₃)₂(CO)(O₂), *trans*-CH₃Ir(P(*p*-tolyl)₃)₂(CO), OP(*p*-tolyl)₃, OPPh₃, P(*p*-tolyl)₃, and PPh₃ to the reaction sample separately and recording the ³¹P NMR spectrum. The reaction did, however, occur with some side reaction as evidenced by the growth of a small resonance at δ -11. There was no oxidation of *p*-tolylphosphine nor substitution of the P(*p*-tolyl)₃ ligand by PPh₃. This suggests that prior coordination of the phosphine is not necessary for oxidation in this system. This is in contrast to the conclusion for other systems.¹⁷

CH₃Ir(P(*p*-tolyl)₃)₂(CO)(O₂) reacted with SO₂ to yield the coordinated sulfate compound, CH₃Ir(P(*p*-tolyl)₃)₂(CO)(SO₄). Oxidation of SO₂ is a common reaction for low-valent dioxygen complexes. The mode of coordination of sulfate can be elucidated by the relative positions of the vibrational frequencies of the sulfate ligand.^{18,19} The sulfate ligand in the CH₃Ir(P(*p*-tolyl)₃)₂(CO)(SO₄) complex coordinates in a chelating, bidentate fashion; the geometry of this complex and the fundamental frequencies attributed to the SO₄ ligand when it is formed by reaction of SO₂ with both CH₃Ir(P(*p*-tolyl)₃)₂(CO)(O₂) and CH₃Ir(P(*p*-tolyl)₃)₂(CO)(¹⁸O₂) are shown in Table IV.

Reaction of CH₃Ir(P(*p*-tolyl)₃)₂(CO)(O₂) with CO₂ leads to the peroxycarbonate, CH₃Ir(P(*p*-tolyl)₃)₂(CO)(OOC(O)O) in quantitative yield. The product is analogous to that reported by Ibers.²⁰ The rate of this oxidation depends directly on the concentration of CH₃Ir(P(*p*-tolyl)₃)₂(CO)(O₂) and shows limiting behavior for the dependence on CO₂ as shown by the data in Figure 1.

Oxidation of CO by a transition-metal dioxygen complex has been observed for platinum, iridium, and rhodium compounds.^{21,22} Characterization of the carbonate complex was done by infrared, ¹H, and ¹³C NMR spectroscopy. The location of the C-O double bond stretches of the carbonate ligand at 1680 and 1620 cm⁻¹ is

(17) (a) Read, G.; Urgelles, M. *J. Chem. Soc., Dalton Trans.* **1986**, 1383. (b) Suzuki, H.; Matsuura, S.; Moro-Oka, Y.; Ikawa, T. *J. Organomet. Chem.* **1985**, *286*, 247-258.

(18) Nakamoto, K. *Infrared and Raman Spectra of Inorganic and Coordination Compounds*, 3rd ed.; Wiley-Interscience: New York, 1978.

(19) (a) Horn, R. W.; Weissberg, E.; Collman, J. P. *Inorg. Chem.* **1970**, *9*, 2367. (b) Valentine, J.; Valentine, D.; Collman, J. P. *Inorg. Chem.* **1971**, *10*, 219.

(20) Mason, M. G.; Ibers, J. A. *J. Am. Chem. Soc.* **1982**, *104*, 5153-5157.

(21) Hayward, P. J.; Blake, D. M.; Wilkinson, G.; Nyman, C. J. *J. Am. Chem. Soc.* **1970**, *92*, 5873-5878.

(22) Siegl, W. O.; Lapporte, S. J.; Collman, J. P. *Inorg. Chem.* **1971**, *10*, 2158-2165.

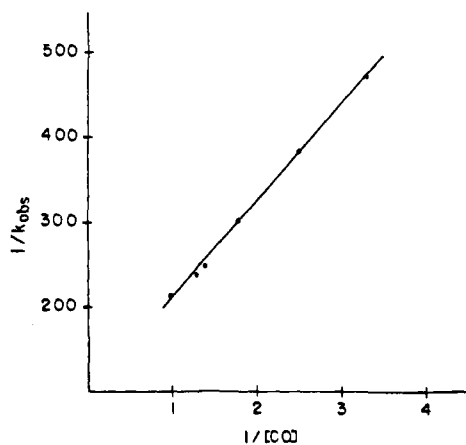

Figure 2. Dependence of k_{obs} on the concentration of CO as shown by a plot of $1/k_{\text{obs}}$ versus $1/[\text{CO}]$.

Table V. Kinetic Data from Reaction of $\text{CH}_3\text{Ir}(\text{P}(p\text{-tolyl})_3)_2(\text{CO})(\text{O}_2)$ with CO (1 atm)

T , °C	solvent	k_{obs} , s^{-1}
50	1,2-dichloroethane	4.0×10^{-4}
50	tetrahydrofuran	1.8×10^{-4}
50	benzene	7.7×10^{-5}
42	benzene	4.2×10^{-5}
33	benzene	1.8×10^{-5}

in excellent agreement with that seen for the other iridium carbonate complexes.²² The proton NMR containing a triplet in the alkyl region indicates that the methyl group is still directly attached to the metal. The ^{13}C NMR data were collected on a sample that was synthesized by reaction of $\text{CH}_3\text{Ir}(\text{P}(p\text{-tolyl})_3)_2(\text{CO})(\text{O}_2)$ and ^{13}CO , and the singlet resonance at 162 ppm is typical for a metal carbonate complex.²³

The reaction between $\text{CH}_3\text{Ir}(\text{P}(p\text{-tolyl})_3)_2(\text{CO})(\text{O}_2)$ and CO was run at three different temperatures (33, 42, and 50 °C) in benzene solution. An Eyring plot gave ΔS^\ddagger of -21 eu (± 6) and ΔH^\ddagger of 15.7 kcal/mol (± 1.7). The value of the entropy of activation of -20 eu indicates an associate pathway. The $[\text{CO}]$ dependence shows limiting behavior as shown in Figure 2.

Data were also obtained by examining the changes in rate observed when various solvents were used for the reaction. The relative reaction rates increase with solvent polarity. The solvent effect is not large yet indicates that the reaction proceeds through a polar intermediate. Such an intermediate could form by cleavage of one metal–oxygen bond of the dioxygen ligand forming a charged monodentate peroxy ligand. The activation parameters and the rate data for the solvent dependence are listed in Table V.

The results of reactions between $\text{CH}_3\text{Ir}(\text{P}(p\text{-tolyl})_3)_2(\text{CO})(\text{O}_2)$, with isotopic labels in the carbon or oxygen atom of the carbonyl ligand, the oxygen atoms on the dioxygen ligand, or with no isotopic labeling, with CO, ^{13}CO , or C^{18}O are summarized in Table II. The intensity of the band resulting from isotopic substitution changed depending on the type of isotopic label. The reaction of $\text{CH}_3\text{Ir}(\text{P}(p\text{-tolyl})_3)_2(\text{CO})(\text{O}_2)$ with C^{18}O resulted in a band in the carbonate product at 1250 cm^{-1} that had an intensity less than that at 1267 cm^{-1} . When $\text{CH}_3\text{Ir}(\text{P}(p\text{-tolyl})_3)_2(\text{CO})(^{18}\text{O}_2)$ was reacted with CO, the $\nu_{\text{C=O}} = 1250\text{ cm}^{-1}$ was greater in intensity than that for the neighboring absorbance at 1267 cm^{-1} . In both of these, the relative amounts of sample in the KBr pellet and isotopic enrichment were the same (based on the relative sizes of peaks in the C=O stretch region). On the basis of this qualitative observation, it appears that relative amounts of enrichment in the carbon–internal oxygen position of the carbonate

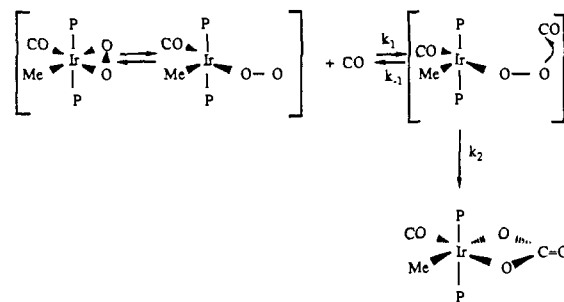

Figure 3. Suggested mechanism for the oxidation of CO by $\text{CH}_3\text{Ir}(\text{P}(p\text{-tolyl})_3)_2(\text{CO})(\text{O}_2)$.

ligand depend on the source of ^{18}O . This result is in agreement with what is predicted on the basis of the relative amounts of isotopic labeling in the reactants and the possible positions of the labels in the carbonate ligand of the product.

Reaction of $\text{CH}_3\text{Ir}(\text{P}(p\text{-tolyl})_3)_2(\text{CO})(^{18}\text{O}_2)$ and CO produced a carbonate product with an ^{18}O label in the external position of the carbonate ligand, suggesting that one of the metal–oxygen bonds must have been cleaved during the carbon monoxide addition. In addition, the presence of an ^{18}O label in both oxygen atom positions of the carbonate ligand when $\text{CH}_3\text{Ir}(\text{P}(p\text{-tolyl})_3)_2(\text{CO})(\text{O}_2)$ is reacted with C^{18}O suggests that there is a scrambling of all of the oxygen atoms during the formation of the carbonate product. The isotopic labeling demonstrates that there is no participation of the coordinated carbonyl ligand of the dioxygen complex in the formation of the carbonate ligand.

Reactions of ethylene, cyclohexene, and dimethyl maleate resulted in no reaction or only in decomposition of the dioxygen complex after long reaction times. When $\text{CH}_3\text{Ir}(\text{P}(p\text{-tolyl})_3)_2(\text{CO})(\text{O}_2)$ reacted with tetracyanoethylene (TCNE), an apparent displacement of the dioxygen ligand by TCNE occurred. A similar reaction has been reported for $\text{Ni}(t\text{-BuNC})_2\text{O}_2$ with TCNE.²⁴ The reaction of TCNE with *trans*- $\text{CH}_3\text{Ir}(\text{P}(p\text{-tolyl})_3)_2(\text{CO})$ produced a compound with absorbances at 2060, 2213, and 2160 cm^{-1} . This same product was isolated when the product from reaction of $\text{CH}_3\text{Ir}(\text{P}(p\text{-tolyl})_3)_2(\text{CO})(\text{O}_2)$ with TCNE ($\nu = 2030, 2150, 2193\text{ cm}^{-1}$) was allowed to sit in a benzene solution for several days. The relative positions of the stretches of these products compared to those seen for the kinetic and thermodynamic isomers of $\text{C}_2(\text{CO}_2\text{CH}_3)_2$ adducts of *trans*- $\text{CH}_3\text{Ir}(\text{PPh}_3)_2(\text{CO})$ ²⁵ ($\nu_{\text{CO}} = 1945, 1975$, respectively) suggest that a similar isomer pair has been prepared.

Attempted reactions between $\text{CH}_3\text{Ir}(\text{P}(p\text{-tolyl})_3)_2(\text{CO})(\text{O}_2)$ and benzyl alcohol, isopropyl alcohol, benzaldehyde, propionaldehyde, acetone, and cyclohexyl isocyanide provided no evidence for oxidation or formation of cyclic intermediates.

Proposed Mechanism. A primary mechanistic question in oxidation reactions involving transition-metal dioxygen complexes is whether the substrate is coordinated to the metal prior to oxidation. Data have been presented supporting both possibilities.^{17,26} In oxidation of CO by $\text{CH}_3\text{Ir}(\text{P}(p\text{-tolyl})_3)_2(\text{CO})(\text{O}_2)$ the isotopic labeling clearly shows that the CO initially coordinated to the metal is not oxidized, casting doubt on coordination prior to oxidation. The oxidation of CO_2 and PPh_3 provide further data relevant to whether the substrate is coordinated to the metal prior to oxidation. In the oxidation of PPh_3 by $\text{CH}_3\text{Ir}(\text{P}(p\text{-tolyl})_3)_2(\text{CO})(\text{O}_2)$ there is no evidence for oxidation of $\text{P}(p\text{-tolyl})_3$. If the PPh_3 were coordinated, it would be cis to the dioxygen, just as the $\text{P}(p\text{-tolyl})_3$ ligands are cis, and the observed selectivity would be difficult to explain. Also, the oxidations of CO and CO_2 are slower than oxidation of PPh_3 . If coordination of CO and CO_2 were necessary, one would expect to see oxidation of the $\text{P}(p\text{-tolyl})_3$

(23) (a) Darensbourg, D. L.; Sanchez, K. M.; Rheingold, A. L. *J. Am. Chem. Soc.* **1987**, *109*, 290–292. (b) Lundquist, E. G.; Foltling, K.; Huffman, J. C.; Caulton, K. G. *Inorg. Chem.* **1987**, *26*, 205–208. (c) Strom, E. T.; Woessner, D. E.; Smith, W. B. *J. Am. Chem. Soc.* **1981**, *103*, 1255–1256. (d) Woon, T. C.; O'Connor, M. J. *Aust. J. Chem.* **1979**, *32*, 1661–1667.

(24) Sheldon, R. A.; Van Doorn, J. A. *J. Organomet. Chem.* **1975**, *94*, 115–129.

(25) Rees, W. M.; Churchill, M. R.; Fettingler, J. C.; Atwood, J. D. *J. Organomet. Chem.* **1987**, *319*, 411–422.

(26) Roundhill, D. M.; Allen, G. A.; Bechtold, R. A.; Beaulieu, W. B. *Inorg. Chim. Acta* **1981**, *54*, L99–100.

Table VI. Relative Rates of Reaction of CH₃IrL₂(CO)(O₂) with CO as the Phosphine Ligands Are Varied

L	$k_{\text{obs}}, \text{s}^{-1}$
PPh ₂ Me	60
P(<i>p</i> -C ₆ H ₄ OMe) ₃	7.8
P(<i>p</i> -tolyl) ₃	4.6
PPh ₃	4.2

ligand; this is not observed. Thus a mechanism for oxidation without prior coordination to the metal is indicated.

The mechanism must accommodate a dependence on the nature of the substrate and limiting behavior on the concentration with a rate law

$$\text{rate} = k_{\text{obs}}[\text{RIrL}_2(\text{CO})(\text{O}_2)] \quad (2)$$

where

$$k_{\text{obs}} = \frac{k[\text{CO}]}{1 + k'[\text{CO}]} \quad (3)$$

This rate law is very similar to that observed for enzymatic reactions that are described by the Michaelis–Menten equation.²⁷ The most probable mechanism is shown in Figure 3. This scheme incorporates an equilibrium between the mono- and bidentate dioxygen complex which is rapid and not a contributing factor to the overall kinetic scheme. The formation of the initial substrate–metal intermediate is in equilibrium with CH₃Ir(P(*p*-tolyl)₃)₂(CO)(O₂), and it is this equilibrium that is dependent on substrate concentration at low substrate concentration. The rate equation describing this scheme is

$$\text{rate} = k_{\text{obs}}[\text{CH}_3\text{Ir}(\text{O}_2)\text{L}_2(\text{CO})] \quad (4)$$

where

$$k_{\text{obs}} = \frac{K_1 k_2 [\text{CO}]}{1 + K_1 [\text{CO}]} \quad (5)$$

Rearrangement of this equation results in the expression

$$\frac{1}{k_{\text{obs}}} = \frac{k_{-1}}{k_2 k_1} \frac{1}{[\text{CO}]} + \frac{1}{k_2} \quad (6)$$

(27) Engel, P. C. *Enzyme Kinetics*; Wiley: New York, 1977; p 14.

and a plot of $1/k_{\text{obs}}$ vs $1/[\text{CO}]$ gives a straight line (Figure 2) with slope of $k_{-1}/k_2 k_1$ and intercept of $1/k_2$. The activation parameters and solvent dependence are also consistent with this mechanism. This mechanism is drawn for CO oxidation but also provides the best description for oxidation of CO₂. Ibers previously suggested that CO₂ was not coordinated prior to oxidation by an iridium dioxygen complex.²⁰ Oxidation of PPh₃ also does not appear to involve coordination prior to oxidation and may occur by a scheme similar to that in Figure 3. We have no definitive data on oxidation of SO₂ but note that the dependence on the nature of the substrate is consistent with the scheme presented in Figure 3.

Changes in Oxidation Rates with Changes in Phosphine Ligand.

Increased electron density at the metal would be expected to increase the reactivity of the free end of the peroxy ligand. The bulk of the ligands cis to the dioxygen ligand however would limit the approach of substrate molecules to the reactive peroxy moiety. To determine if these steric and electronic effects are important, a series of compounds, RIrP₂(CO)(O₂) (P = PPh₃, P(*p*-tolyl)₃, P(*p*-C₆H₄OCH₃)₃, PPh₂Me), were reacted with CO. The rate data for these reactions are listed in Table VI. These data indicate that steric interactions are more important than electronic factors. This would be anticipated for a complex with the phosphine ligands cis to the reactive site.

Conclusions

This study has examined the synthesis and reactivity of complexes of the type RIrP₂(CO)(O₂). A survey of the reactivity of CH₃Ir(P(*p*-tolyl)₃)₂(CO)(O₂) showed that it is relatively inert to most unactivated substrates except for CO, CO₂, and SO₂, where the oxidized substrates become coordinated to the metal as bidentate ligands. Mechanistic studies of the oxidation of CO and CO₂ suggest that the reactions proceed by similar pathways, and there is no evidence to suggest that these pathways involve substrate coordination prior to oxidation. Results of the variation of phosphine ligands suggest that the bulk of the substituents on the phosphine has greater influence over controlling the reactivity of the peroxy ligand than does the basicity of the phosphine.

Acknowledgment. We thank the National Science Foundation (CHE-8709563) and the donors of the Petroleum Research Fund, administered by the American Chemical Society, for support of this research. A loan of IrCl₃·xH₂O was provided by Johnson Matthey, Inc.